

FSL 113

FOR FLOORS WITH LARGE MOVEMENT – TO BE USED BY LIGHT FORK LIFT TRUCKS AND PALLET TRUCKS

MIGUTRANS

HEAVY-DUTY ALL-METAL JOINT SOLUTIONS FOR LARGE TRAFFIC LOADS

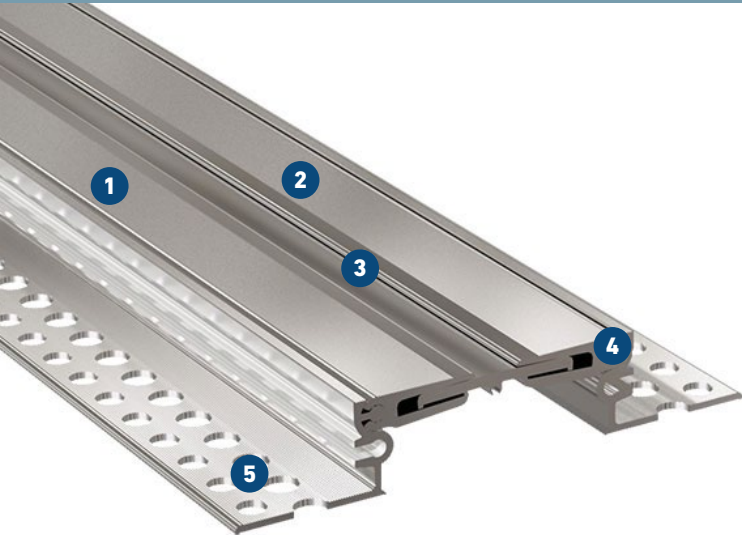

- 1 Solid all-metal expansion joint cover**
hard wearing, maintenance-free, long lasting
- 2 Striated surface**
ensures good skid resistance
- 3 Symmetrical visible surface without gaps**
prevents accumulation of dirt
- 4 Articulated telescoping system**
absorbs movement in 3 directions
- 5 MultiHole mounting bracket**
for secure fixing

Expansion joint cover	Joint width max. b_f [mm]	Total movement Δb_f [mm]	Visible width b_s [mm]	Total width b_t [mm]	Joint height h [mm]	Load bearing capacity  [kN]
FSL 113/20	90	45 ($\pm 22,5$)	113	200	20	12
FSL 113/35	90	45 ($\pm 22,5$)	113	200	35	12
FSL 113/50	90	45 ($\pm 22,5$)	113	200	50	12
FSL 113/90	90	45 ($\pm 22,5$)	113	200	90	12

Production length: 4 m

Standard colour: Aluminium

Larger installation heights on request.

